



EB-TA2022

CLASS-T DIGITAL AUDIO AMPLIFIER 2 CHANNEL TA2022 EVALUATION BOARD

Technical Information

Revision 1.0 – March 2002

GENERAL DESCRIPTION

The EB-TA2022 Version 4.0 is a stereo 100W per channel audio amplifier designed to provide a simple and straightforward environment for the evaluation of the TA2022 amplifier. This evaluation board includes a circuit that will automatically trim any DC offset at the output and a relay. For additional documentation on the TA2022, see the TA2022 Data Sheet.

APPLICATIONS

- Mini/Micro Component Systems
- Home Theater Receivers
- Car stereo head units & trunk amplifiers
- Powered DVD Systems

BENEFITS

- More power per cubic inch for 100W per channel design
- Simplifies thermal management
- Signal Quality comparable to linear amplifiers
- Simple building block for multi-channel design

FEATURES

- High Power: 100W @ 4Ω, 1.0% THD+N
- Low Noise Floor: 150uV A-weighted
- Low Distortion: .02% THD+N @ 75W, 4Ω
- High Efficiency: 92% for 8Ω loads
87% for 4Ω loads
- Dynamic Range = 102dB
- Over-Current Protection
- Over and Under Voltage Protection
- Over Temperature Protection
- Single Ended Outputs

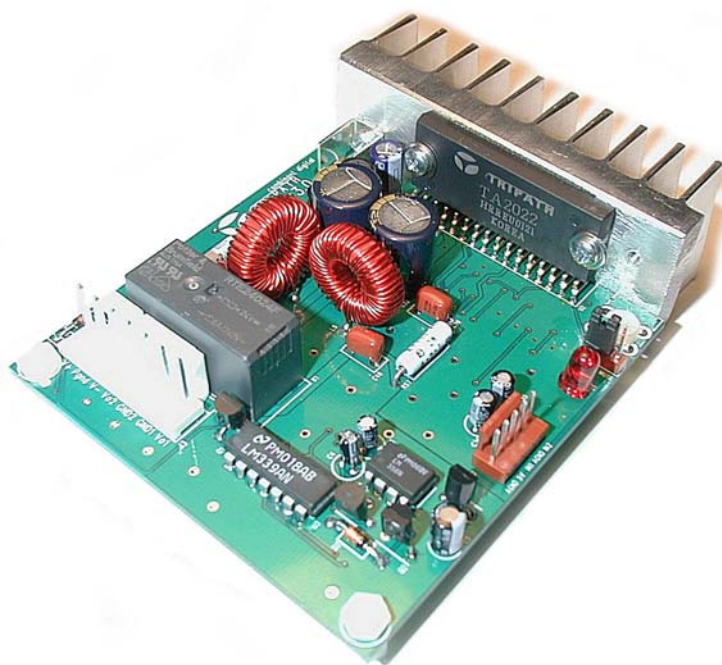

OPERATING INSTRUCTIONS

BOARD CONNECTION DIAGRAM

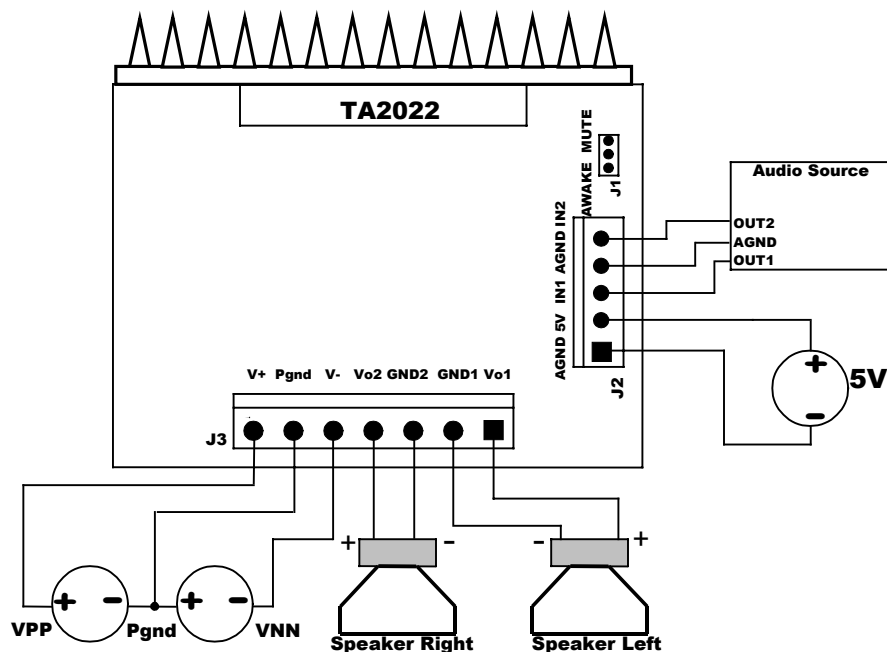

Three external power supplies are required to operate the EB-TA2022: VPP, VNN (referenced to Pgnd), and 5V (referenced to Agnd). The VPP and VNN form a split rail supply referenced to Pgnd. The 5V ground (Agnd) must be kept separate from the VPP and VNN ground (Pgnd). Agnd and Pgnd are joined at a common point on the EB-TA2022 near headers J2 and J3.

Minimum and Maximum supply voltages are +/-20V and +/-36V, respectively, depending on the load impedance. It is not recommended that the EB-TA2022 be operated above +/-31V when driving 4Ω loads, single ended, as the internal current limit circuit may activate, causing the amplifier to mute.

The VPP and VNN power supply connection, J3, is through a 7-Pin 0.156" spaced header. The female terminal housing for this header is Molex 09-50-8071. Please see TABLE 2 for header connections.

The 5V power supply connection, J2, is through a 5-Pin 0.100" spaced header. The female terminal housing for this header is Molex 22-01-2057. Please see TABLE 1 for header connections.

TABLE 1

J2 Connector Pin#	Connection
Pin1	Agnd
Pin2	5V
Pin3	IN1
Pin4	Agnd
Pin5	IN2

TABLE 2

J3 Connector Pin#	Connection
Pin1	Vo1
Pin2	GND1
Pin3	GND2
Pin4	Vo2
Pin5	VNN
Pin6	Pgnd
Pin7	VPP

OUTPUT

The output connection for each channel of the EB-TA2022 is made at pins 1 – 4 of header J3. The output of the TA2022 is single-ended, therefore each output has a positive output (Vo1 and Vo2) and a ground (GND1 and GND2).

INPUT

The input connection for each channel of the EB-TA2022 is made at pins 3 – 5 of header J2. The left and right inputs should be connected to IN1 (pin3) and IN2 (pin5). These inputs share a common ground referenced to Agnd (pin4).

JUMPER SETTINGS

There is a 3-pin header for the MUTE control of the TA2022. With the jumper placed in the AWAKE position the part is un-muted by grounding (AGND) the mute pin. When the jumper is placed in the MUTE position the mute pin is pulled high (5V) and the amplifier is muted.

OUTPUT OFFSET NULL AND RELAY

There is an automatic offset trim circuit for each channel using an LM358 op-amp. Once the LM358 trims any DC to 0Vdc a comparator allows a relay to close.

GAIN SETTING

The gain of the EB_TA2022 Version 4.0 is set to 18V/V. The gain of the TA2022 is the product of the input stage and the modulator stage. The input stage gain is set to unity. Before changing the gain of the TA2022, please refer to the TA2022 Amplifier Gain section of the TA2022 Data Sheet.

Performing Measurements on the EB-TA2022 Version 4.0

The TA2022 operates by generating a high frequency switching signal based on the audio input. This signal is sent through a low-pass filter that recovers an amplified version of the audio input. The frequency of the switching pattern is spread spectrum in nature and typically varies between 100kHz and 1MHz, which is well above the 20Hz – 20kHz audio band. The pattern itself does not alter or distort the audio input signal, but it does introduce some inaudible components.

The measurements of certain performance parameters, particularly noise related specifications such as THD+N, are significantly affected by the design of the low-pass filter used on the output as well as the bandwidth setting of the measurement instrument used. Unless the filter has a very sharp roll-off just beyond the audio band or the bandwidth of the measurement instrument is limited, some of the inaudible noise components introduced by the TA2022 amplifier switching pattern will degrade the measurement by including out of band (audio) energy.

One feature of the TA2022 is that it does not require large multi-pole filters to achieve excellent performance in listening tests, usually a more critical factor than performance measurements. Though using a multi-pole filter may remove high-frequency noise and improve THD+N type measurements (when they are made with wide-bandwidth measuring equipment), these same filters degrade frequency response. The EB-TA2022 has a simple two-pole output filter with excellent performance in listening tests.

(See Application Note 4 for additional information on bench testing)

Contact Information

TRIPATH TECHNOLOGY, INC

2560 Orchard Parkway, San Jose, CA 95131
408.750.3000 - P
408.750.3001 - F

For more Sales Information, please visit us @ www.tripath.com/cont_s.htm

For more Technical Information, please visit us @ www.tripath.com/data.htm

EB-TA2022 Revised: 3/18/2001 JR.
Revision: Ver4.0

Bill Of Materials

Item	Quantity	Reference	Part	Digikey Part #	Manufacturers Part# (Package)
1	10	C33,C41,C42,C43,C48, C49,C3,C8,C9,C10	0.1uF;50V	PCC1864CT-ND	Panasonic ECJ-2VF1H104Z (SMT 0805)
2	2	C44,C45	0.1uF;100V		AVX-12061C104KAT2A (SMT 1206)
3	1	C47	390pF;50V	PCC391CGCT-ND	PANASONIC ECJ-2VC1H391J(SMT 0805)
4	1	C46	330pF;50V	PCC331CGCT-ND	PANASONIC ECJ-2VC1H331J(SMT 0805)
5	2	C35,C36,C4,C6	3.3uF;25V	P6626-ND	Panasonic ECE-A25Z3R3(Thru-Hole)
6	4	C37,C38,C39,C40	0.22uF;50V	P4667-ND	Panasonic ECQ-V1H224JL(Thru-Hole)
7	2	C29,C32	220uF;50V	P10326-ND	Panasonic EEU-FC1H221S(Thru-Hole)
8	1	C34	100uF;35V	P5165-ND	Panasonic ECA-1VM101(Thru-Hole)
9	2	C27,C28	47uF;16V	P810-ND	Panasonic ECE-A1CKA470(Thru-Hole)
10	1	C5	22uF, 10V	P960-ND	Panasonic ECE-A1AKS220(Thru-Hole)
11	3	D1,D8,D9	B1100/B	B1100DICT-ND	Diodes Incorporated (SMA)
12	4	D5,D11,D12,D13	MURS120T3		MURS120T3 (SMT SMB)
13	1	D4	1N5243	1N5243BDICT-ND	13V, 500mW, DO-35
14	1	D2	1N5235	1N5235BDICT-ND	6.8V, 500mW, DO-35
15	1	D3	1N4148	1N4148DICT-ND	DO-35
16	1	D6	LED		
17	1	J3	7-pin,0.156" header	WM4605-ND	Molex 26-48-1075
18	1	J2	5-pin,0.100" header	WM4203-ND	Molex 22-23-2051
19	1	J1	3-pin,0.100" header	WM4001-ND	Molex 22-03-2031
20	2	J9,J10	Screw Terminal	8190K-ND	Keystone 8190
21	1	L4	100uH	TK4300-ND	JWMiller 6000-101k or Toko 187LY-101J
22	2	L5,L6	11uH		PA0291(Pulse Engineering)*see note 1
23	2	R47,R48	249W		(SMT 0805)
24	1	R16	300W		(SMT 0805)
25	5	R30,R33,R34,R35,R50	1KW		(SMT 0805)
26	4	R36,R38,R39,R40	1.2KW		(SMT 0805)
27	2	R1,R17	3KW		(SMT 0805)
28	1	R42	8.2KW,1%		(SMT 0805)
29	4	R31,R37,R41,R52	9.1KW,1%		(SMT 0805)
30	2	R18,R19	10KW		(SMT 0805)
31	1	R8	15KW		(SMT 0805)

32	4	R32,R43,R44,R51	20KW, 1%		(SMT 0805)
33	1	R7	25KW		(SMT 0805)
34	1	R9	35KW		(SMT 0805)
35	5	R2,R10,R12,R14,R15	50KW		(SMT 0805)
36	1	R5	80KW		(SMT 0805)
37	3	R3,R11,R13	100KW		(SMT 0805)
38	1	R4	200KW		(SMT 0805)
39	3	R45,R46,R6	249KW,1%		(SMT 0805)
40	2	R56,57	6W;2W	P6.2W-2BK-ND	(2W Thru-hole)
41	1	U2	TA2022		Tripath Technology
42	1	U1	LM358	LM358N-ND	8-Dip
43	1	U3	LM339	LM339N-ND	14-Dip
44	3	Q1,Q2,Q4	2N7000	2N7000FS-ND	TO-92
45	1	Q3	2N3906	2N3906-ND	TO-92
46	1	K1	DPDT RELAY 8A,24V	PB297-ND	RTE24024F
47	4	CON1,CON2,CON3,CON4	3/8"STANDOFF	4801K-ND	
48	4	STANDOFF NUT	HEX 4-40	H616-ND	
49	2	screw terminal(horiz.)	J9,J10	8190k-nd	Keystone 8190
50	2	screw terminal screw	1/4" 4-40	H342-ND	
51	2	TA2022 washer	NO. 4 FLAT	H734-ND	
52	2	TA2022 screw	3/8" 4-40	H781-ND	

Note 1: Inductor selection is critical for optimal operation of the TA2022 as well as being an important component in over current protection and EMI containment. Tripath recommends the customer use a toroidal inductor for all applications with the TA2022. For typical applications we recommend the Micrometals T68-2 core or the American Cores (Amidon) T690-06. This core has a high peak current capability due to its low-m Carbonyl-E metal powder. A distributed air gap increases its energy storage capability, which allows for a small footprint and high current capability. The T68-2 and T690-06 cores have a 17.5mm outer diameter. Forty-four turns of 22AWG wire makes a complete single layer winding around the toroid with six to eight layers overlapping yielding an ideal value of 11uH. This winding pattern, which covers the core completely, aids in shielding the electric field. It should be noted that when multiple layers are used there may be an increase in winding capacitance, which can cause ringing and increased radiated emissions. Winding techniques, such as bank winding, can minimize this effect. It is important that the initial windings not be crossed over by the last few windings. If a few windings more than the single layer are required it is best to wind the core with a full single layer, back off a number of turns, and rewind over the last few windings. A larger diameter Carbonyl-E core may be used if a single layer wound core is required. If a smaller core is required, a 15.2mm outer diameter Carbonyl-E core may be substituted, though thermal requirements must be considered. Please contact Tripath Applications if there are questions pertaining to this subject.

Substitution Notes:

- 1- ITEM#2- This component must be .1uF, 100V with X7R material characteristic and placed close to pins 4,8 and 9,10 of TA2022 with less than 1/8" lead length to the part.
- 2- ITEM#7- This component should be a high frequency, low ESR capacitor. We recommend .1W, or less and a ripple current rating of at least 1A.
- 3- ITEM#22- This component should be a 10A inductor with very high linearity. Please see Data Sheet for substitution details.
- 4- ITEM#12- This component should be an ultra-fast PN junction rectifier diode with a maximum Vf of 1V at 10A.
- 5- ITEM#11- The Bootstrap Diodes (D8, D9) should be Schottky diodes rated at least 200mA, 100V, 50nS. The VN10 Diode (D1) should be a Fast Recovery, switching, or Schottky diode rated at least 200mA, 30V, 50nS.

TA2022-100

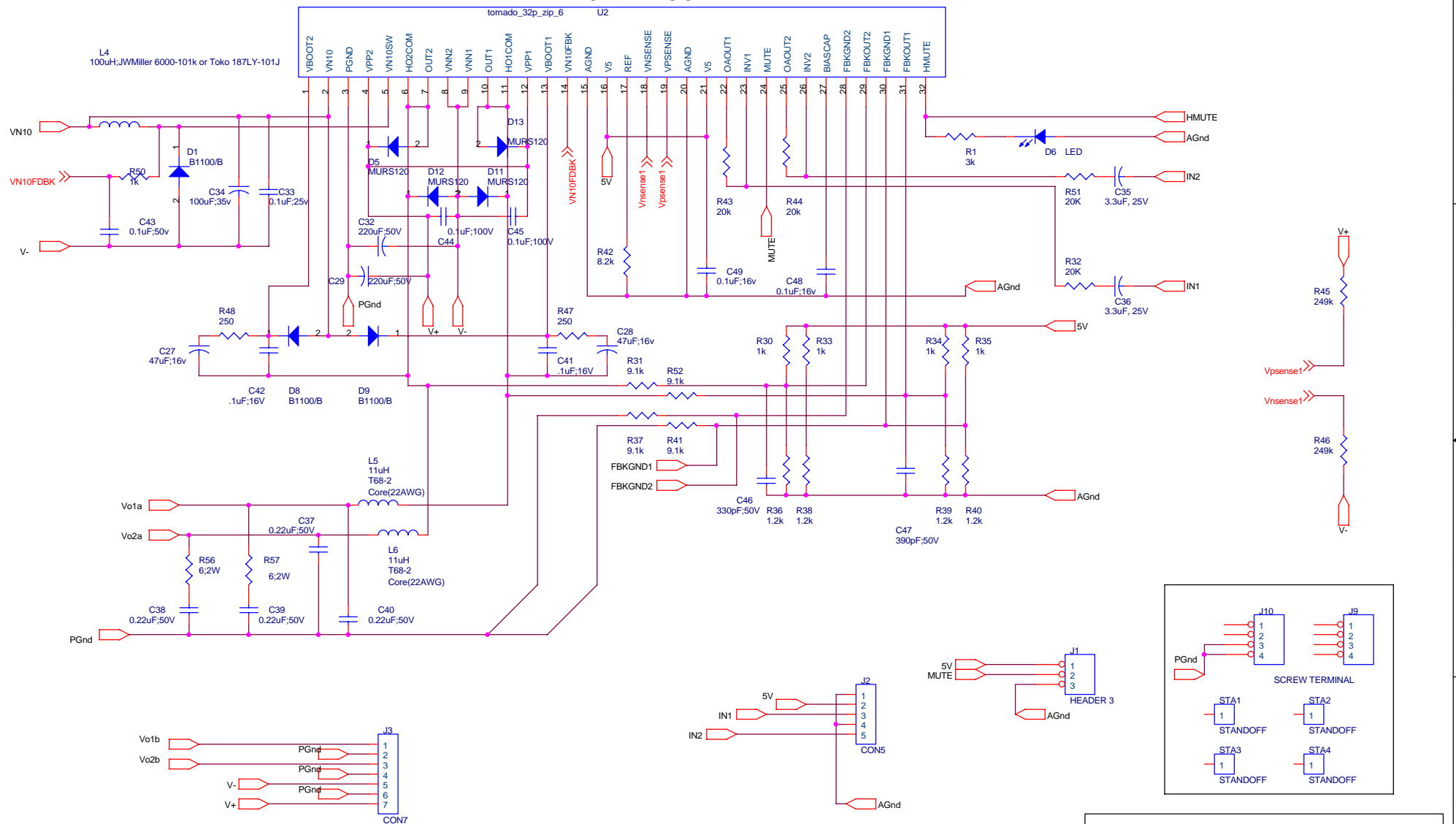

Title		
EB-TA2022 Ver. 4.0		
Size	Document Number	Rev
B	Schematic 1	4.0
Date:	Friday, March 01, 2002	Sheet 1 of 1

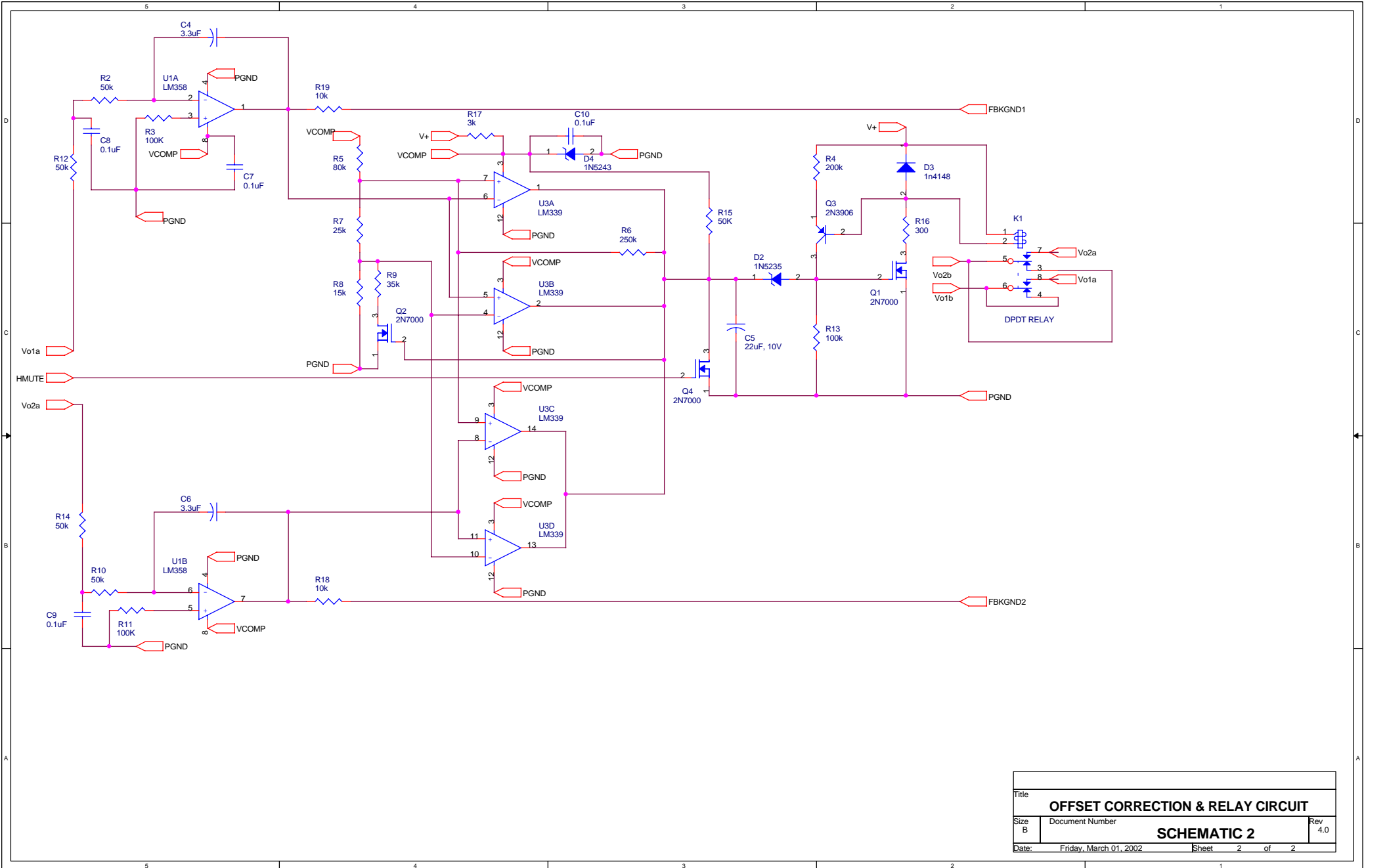

Title		
OFFSET CORRECTION & RELAY CIRCUIT		
Size	Document Number	Rev
B		4.0
Date: Friday, March 01, 2002		Sheet 2 of 2
SCHEMATIC 2		

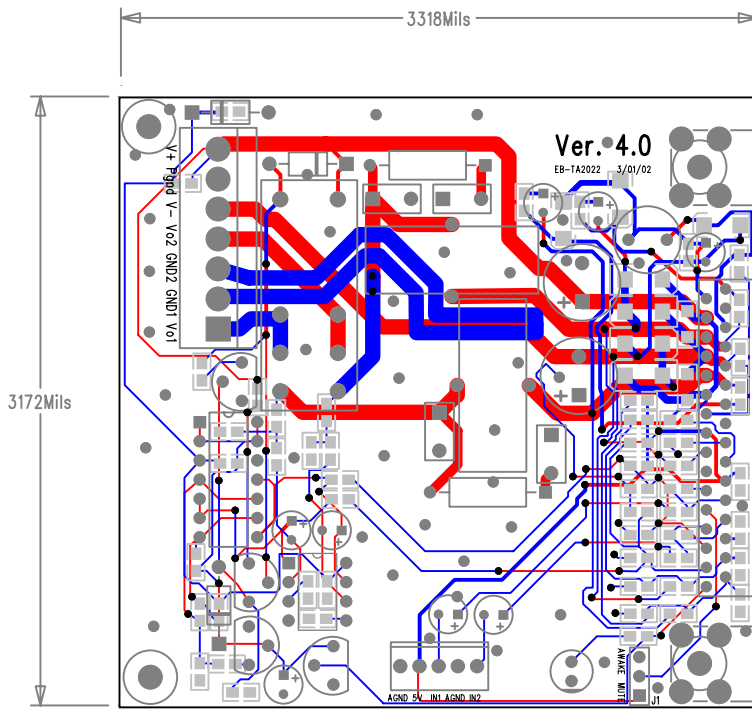

FABRICATION NOTES
 DOUBLE SIDED BOARD
 MATERIAL: .062 FR-4
 2 OZ COPPER, ALL LAYERS

VIEWED FROM TOP SIDE
 COMPOSITE DRAWING

Top Trace RED
 Bottom Trace BLUE
 Top Component DARK GRAY
 Bottom Component LIGHT GRAY

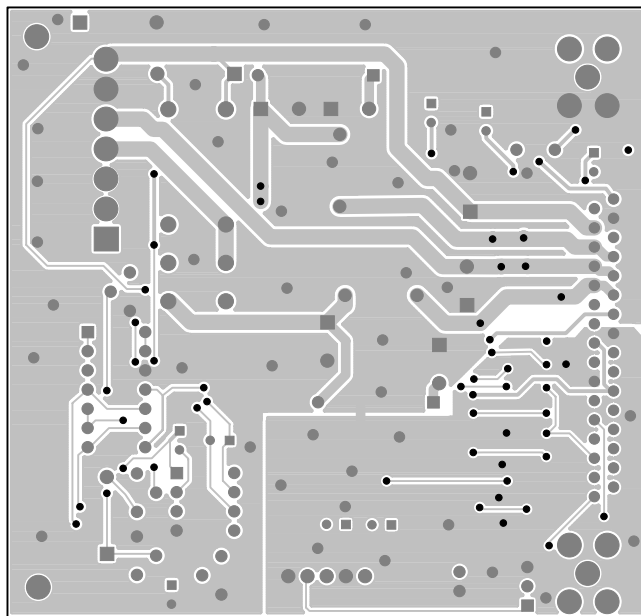

FABRICATION NOTES
DOUBLE SIDED BOARD
MATERIAL: .062 FR-4
2 OZ COPPER, ALL LAYERS

VIEWED FROM TOP SIDE
TOP SIDE ETCH

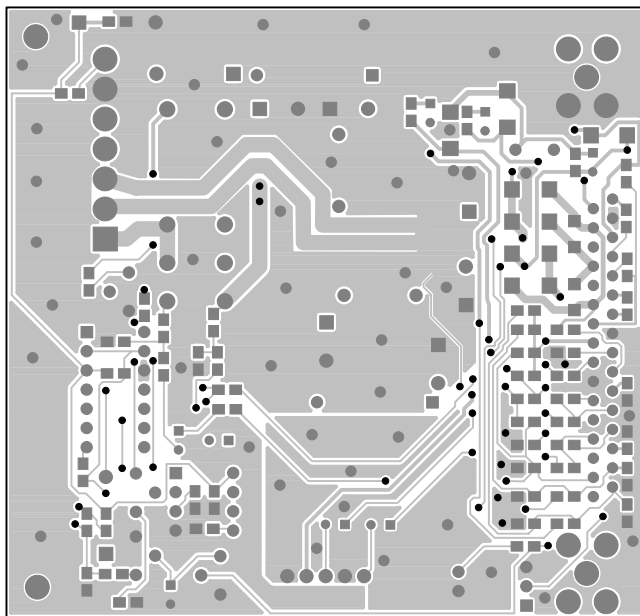

FABRICATION NOTES
DOUBLE SIDED BOARD
MATERIAL: .062 FR-4
2 OZ COPPER, ALL LAYERS

VIEWED FROM TOP SIDE
BOTTOM SIDE ETCH

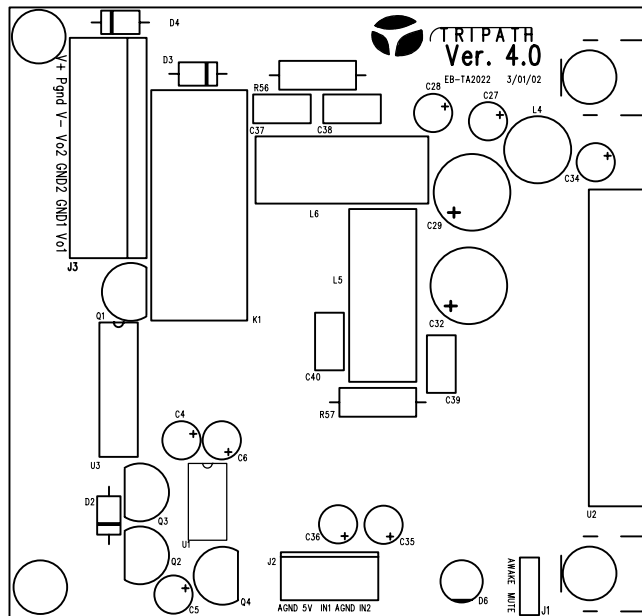

FABRICATION NOTES
 DOUBLE SIDED BOARD
 MATERIAL: .062 FR-4
 2 OZ COPPER, ALL LAYERS

VIEWS FROM TOP SIDE
 SILKSCREEN TOP

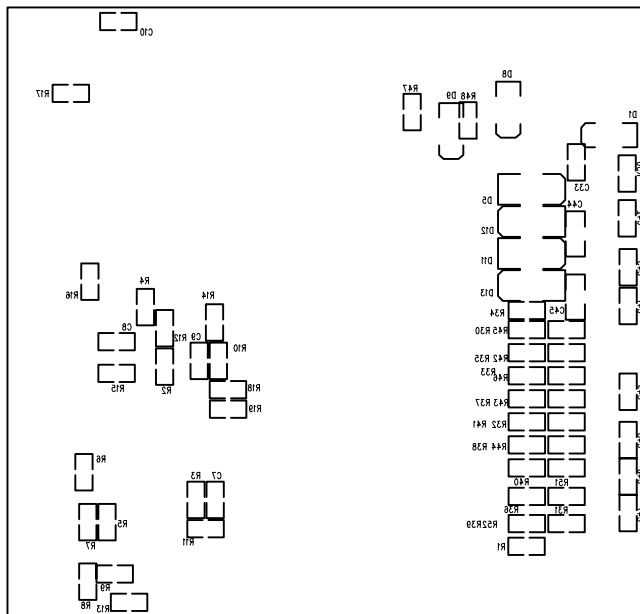

FABRICATION NOTES
 DOUBLE SIDED BOARD
 MATERIAL: .062 FR-4
 2 OZ COPPER, ALL LAYERS

VIEWED FROM TOP SIDE
 SILKSCREEN BOTTOM

This datasheet has been download from:

www.datasheetcatalog.com

Datasheets for electronics components.