

Service Manual



ORDER NO.
ARP2019

FM/AM DIGITAL SYNTHESIZER TUNER **F-757**

MODEL F-757 HAS FOLLOWING VERSIONS:

Type	Power requirement	Export destination
HEWZI	AC220V, 240V (switchable) *	West Germany and Italy
HE	AC220V, 240V (switchable) *	European continent
HB	AC220V, 240V (switchable) *	United Kingdom

* Change the primary wiring of the power transformer.

- This manual is applicable to the F-757/HEWZI, HE and HB types.
- As to the HE and HB types, refer to page 33.
- Ce manuel pour le service comprend les explications de réglage en français.
- Este manual de servicio trata del método ajuste escrito en español.

CONTENTS

1. PANEL FACILITIES.....	2	6. ADJUSTMENTS.....	21
2. EXPLODED VIEWS, PAKING AND PARTS LIST	4	RÉGLAGE.....	24
3. SCHEMATIC DIAGRAM.....	7	AJUSTE.....	27
4. P.C. BOARDS CONNECTION DIAGRAM	11	7. IC INFORMATION.....	30
5. P.C.B'S PARTS LIST.....	17	8. FOR HE AND HB TYPES.....	33
		9. SPECIFICATIONS.....	34

1. PANEL FACILITIES

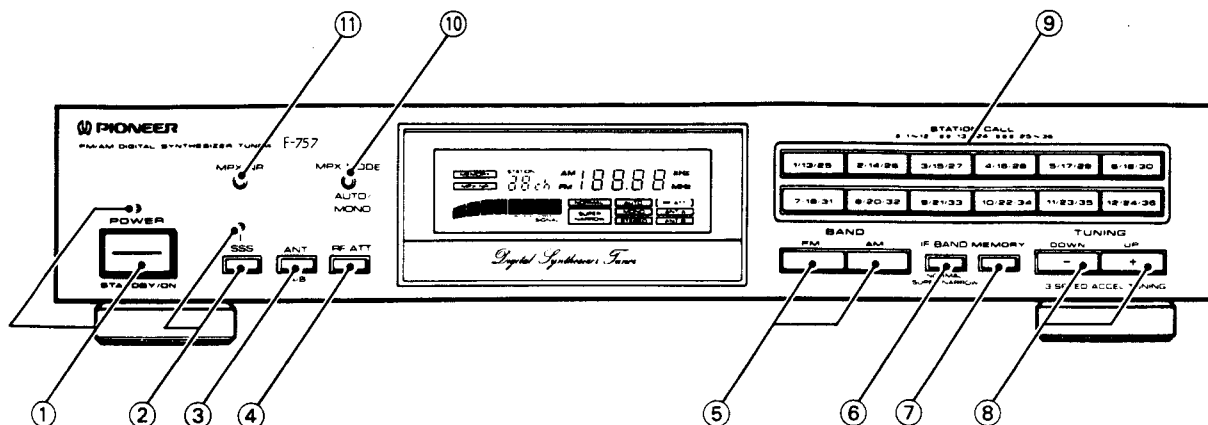

① POWER (STANDBY/ON) switch/indicator

When the power is on, indicator lights.

ON..... When set to ON position, power is supplied and the unit becomes operational

STANDBY When set to STANDBY position, the main power flow is cut and the unit is no longer fully operational. A minute flow of power feeds the unit to maintain operation readiness.

NOTE:

- The memory will be backed up so long as the power cord is not unplugged.
- If the power cord is unplugged, the memory will be retained for several days.

② SSS button/indicator

When SSS is on, indicator lights. If turned on during reception of AM or when MPX MODE is set to MONO during FM, this will produce a simulated stereo effect which provides rich ambience.

SSS: Spectrum Simulated Stereo.

NOTE:

This button's status is preset for each station in station memory.

③ ANT A/B button

Selects between two antennas connected to the FM antenna A and B terminals. **ANT A** or **ANT B** indicator lights up.

NOTE:

This button's status is preset for each station in station memory.

④ RF ATT button

Set this switch to ON when receiving strong FM signals (nearby stations) to reduce sound distortion ([RF ATT] indicator lights). Normally, this switch should be set to OFF.

NOTE:

This button's status is preset for each station in station memory.

⑤ BAND selector buttons

FM:

Press to receive FM broadcasts.

AM:

Press to receive AM broadcasts.

⑥ IF BAND button

Each time this button is pressed the bandwidth of the IF circuit switches between "normal" and "super narrow" for the FM band and the AM band.

The selected bandwidth is displayed as follows:

The **NORMAL** or **SUPER NARROW** indicator lights up.

Set to SUPER NARROW in case of interference from other stations.

NOTE:

The setting of this button is memorized together with the station in the station memory.

⑦ MEMORY button

Press to memorize preset stations. The **MEMORY** indicator will remain lit for several seconds. Press the desired STATION CALL buttons to memorize it during this period.

⑧ TUNING UP/DOWN buttons

Use these buttons to tune in broadcasting stations. Press UP (+) to receive a station whose frequency is higher than the displayed frequency, and DOWN (-) to tune into a lower frequency station.

⑨ STATION CALL buttons

Use these buttons to preset stations and to receive already preset stations.

⑩ MPX (multiplex) MODE button

Mode changes as follows each time this button is pressed:

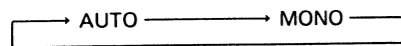

This button does not affect AM reception.

AUTO:

Depending on the broadcast station, STEREO or MONO is automatically selected.

AUTO indicator lights up.

NOTE:

When the signal level is too weak for reception, sound output is automatically muted.

MONO:

To receive stereo broadcasts in monaural.

MONO indicator lights up.

NOTE:

The setting of this button is memorized together with the station in the station memory.

⑪ MPX NR button

When **MPX NR** is on, indicator lights up.

During reception of stereo broadcasts where the signal is weak, set this to ON if noise is a problem. Noise will be suppressed and sound quality will become clearer.

NOTE:

- This button's status is preset for each station in station memory.
- This does not operate during AM signal reception or when the MPX mode is MONO.

OPERATING DISPLAY

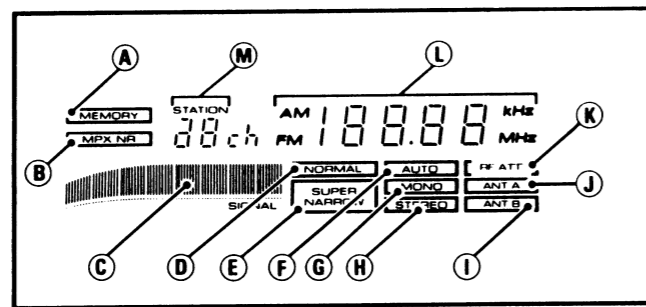

A MEMORY indicator

Lights for a several seconds when MEMORY button is pressed.

B MPX NR indicator

This indicator lights when the MPX NR is operating.

C SIGNAL indicator

Lights when signal is weak.

D NORMAL indicator

Stays lit while IF BAND button is set to NORMAL.

E SUPER NARROW indicator

Stays lit while IF BAND button is set to SUPER NARROW.

F AUTO indicator

Stays lit while MPX MODE button is set to AUTO.

G MONO indicator

Stays lit while MPX MODE button is set to MONO.

H STEREO indicator

Lights up when a stereo broadcast is received. (The indicator does not light when the MPX MODE button is set to MONO.)

I ANT B indicator

Lights when ANT A/B button selects B.

J ANT A indicator

Lights when ANT A/B button selects A.

K RF ATT indicator

Stays lit while RF ATT button is on.

L Frequency indicator

Shows reception band and frequency.

M STATION indicator

When STATION CALL buttons are pressed, it will show the corresponding channel number.

2. EXPLODED VIEWS, PAKING AND PARTS LIST

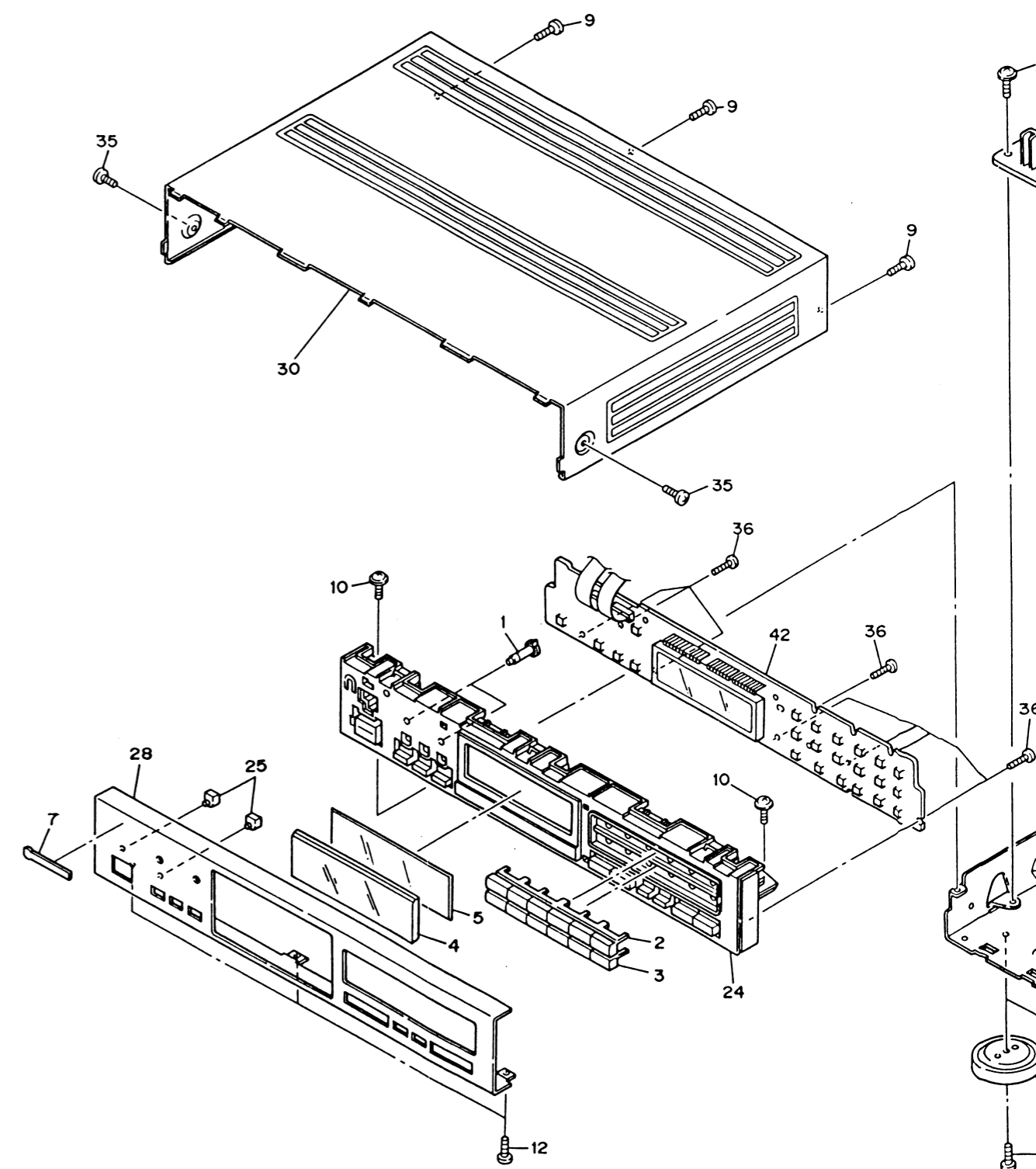

4

5

6

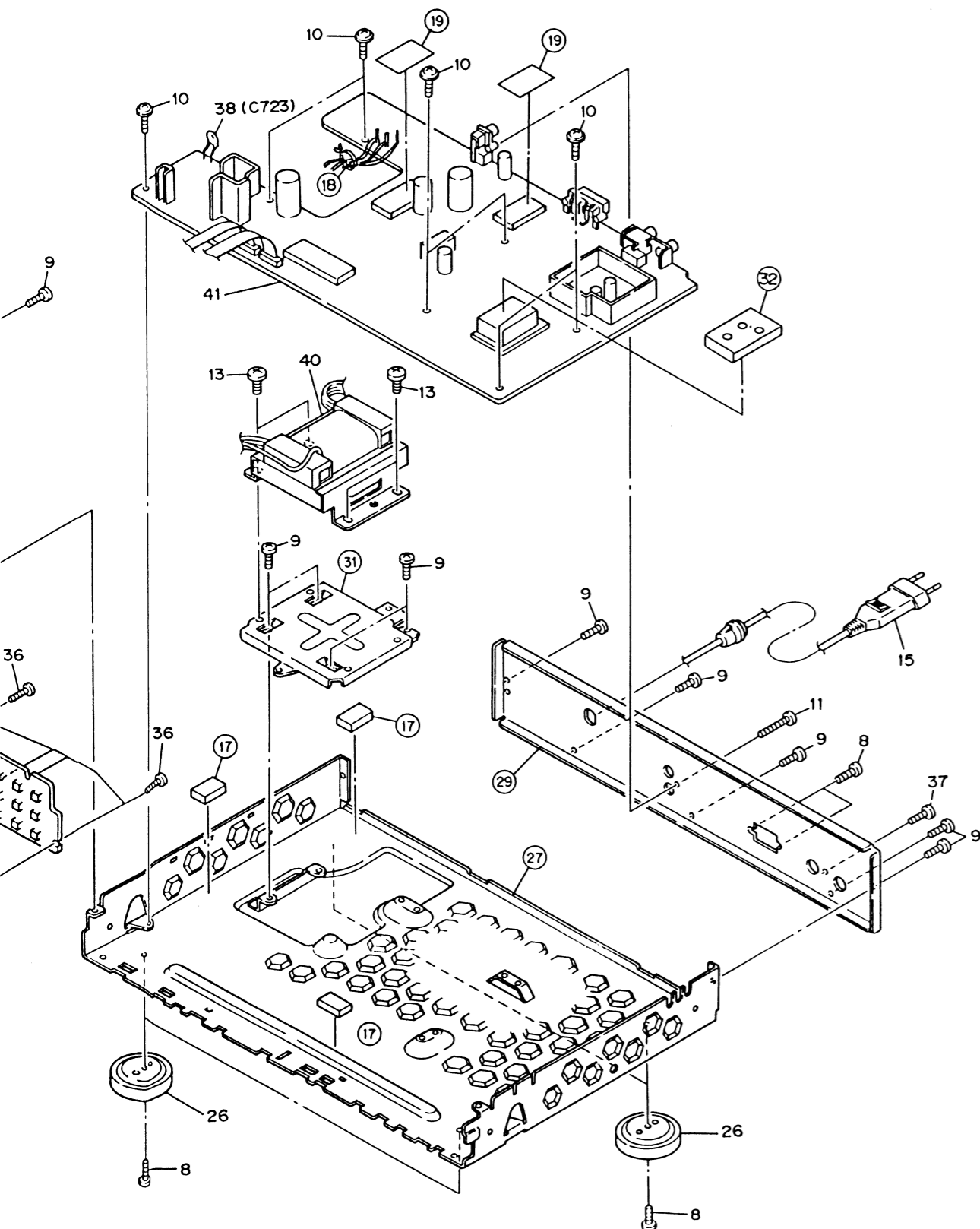

4

5

6



NOTES:

- Parts without part number cannot be supplied.
- Parts marked by "●" are not always kept in stock. Their delivery time may be longer than usual or they may be unavailable.
- The Δ mark found on some component parts indicates the importance of the safety factor of the part. Therefore, when replacing, be sure to use parts of indetical designation.

A

PARTS LIST OF EXTERIOR AND PACKING

Mark	No. & Description	Part No.	Mark	No. & Description	Part No.
	1. TACT BUTTON(PLS)	AAD1733		41. TUNER ASSEMBLY	AWZ2904
	2. STATION BUTTON	AAD1751		42. DISPLAY ASSEMBLY	AWZ2933
	3. STATION BUTTON	AAD1752			
	4. PANEL	AAK1685			
	5. FL FILTER	AAK1785			
	6. ...				
	7. NAME PLATE	AAM1029			
	8. SCREW	ABA-298			
	9. SCREW	ABA1009			
	10. SCREW (STEEL)	ABA1011			
	11. SCREW (STEEL)	ABA1047			
	12. SCREW (STEEL)	ABA1048			
	13. SCREW 4X6	ABA1074			
	14. PULG CORD	ADE-081			
Δ	15. AC POWER CORD	ADG1010			
	16. FM ANTENNA	ADH1002			
	17. CUSSION				
	18. NYLON BINDER				
	19. CU PLATE				
	20. PAD(F/R)	AHA1095			
	21. PACKING CASE	AHD1799			
	22. ...				
	23. PACKING SHEET	AHG1017			
	24. PANEL BASE	AMB1598			
	25. INDICATING LENS	AMR1160			
	26. INSULATOR ASSEMBLY	AMR2140			
	27. CHASSIS ASSEMBLY				
	28. FRONT PANEL	ANB1372			
	29. REAR PANEL				
	30. BONNET	AZN1745			
	31. TRANS. HOLDER				
	32. SHIELD PLATE				
	33. OPERATING INSTRUCTIONS (German, Italian)	ARC1179			
	34. ...				
	35. SCREW	BBT30P060FZK			
	36. SCREW	BPZ26P080FMC			
	37. SCREW	VMZ30P060FCU			
	38. CAPACITOR(C723,0.01μ/AC150V)	ACG1005			
	39. LOOP ANTENNA(AM)	ATB-086			
Δ	40. POWER TRANSFORMER (T701)	ATT1116			

B

● Packing

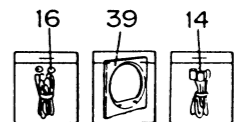

C

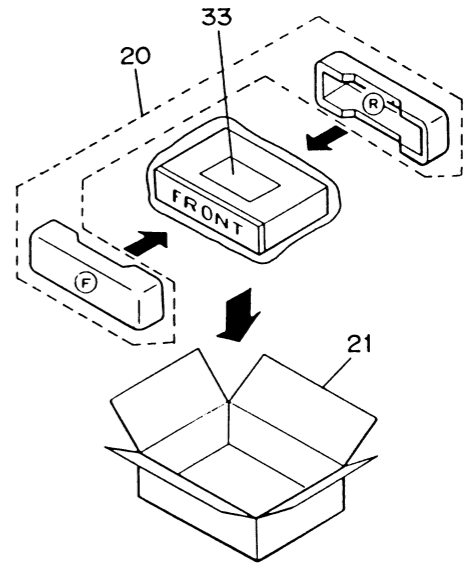

D

3. SCHEMATIC DIAGRAM

A

B

C

D

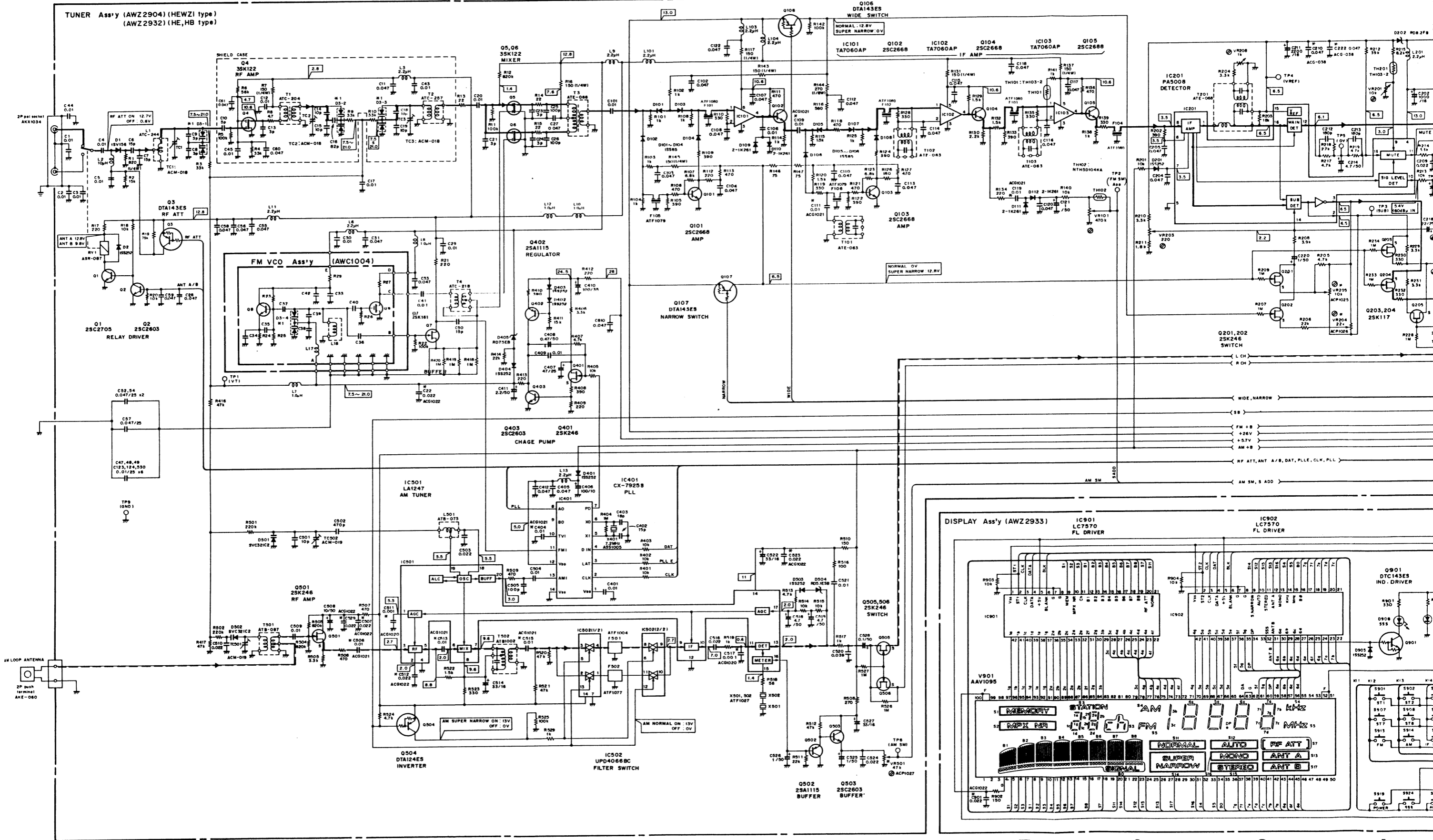

4. P.C.BOARDS CONNECTION DIAGRAM

TUNER ASSEMBLY (AWZ2904) HEWZI TYPE
(AWZ2932) HE, HB TYPE

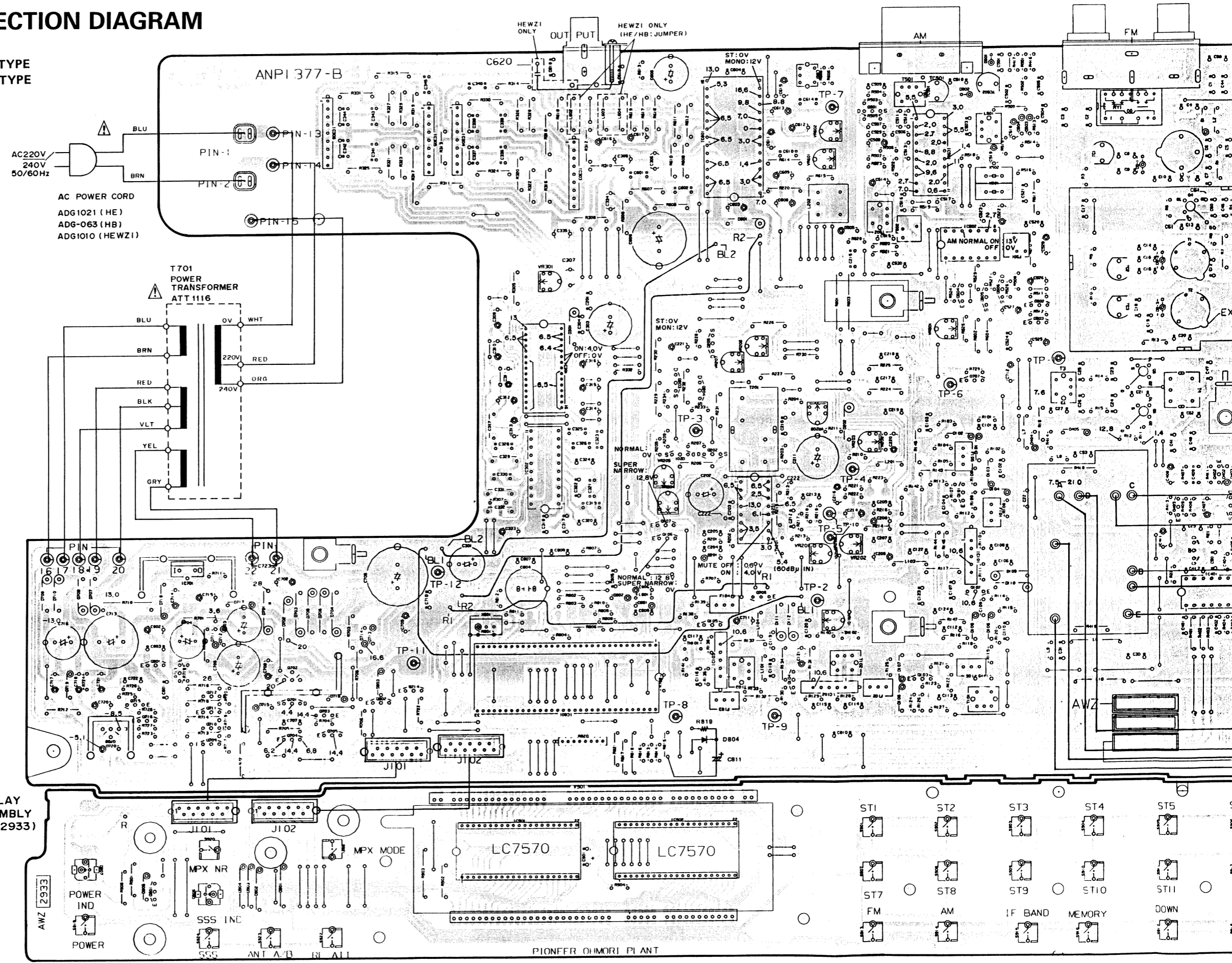

A

B

C

D

1

2

3

4

5

6

1

2

3

4

5

6

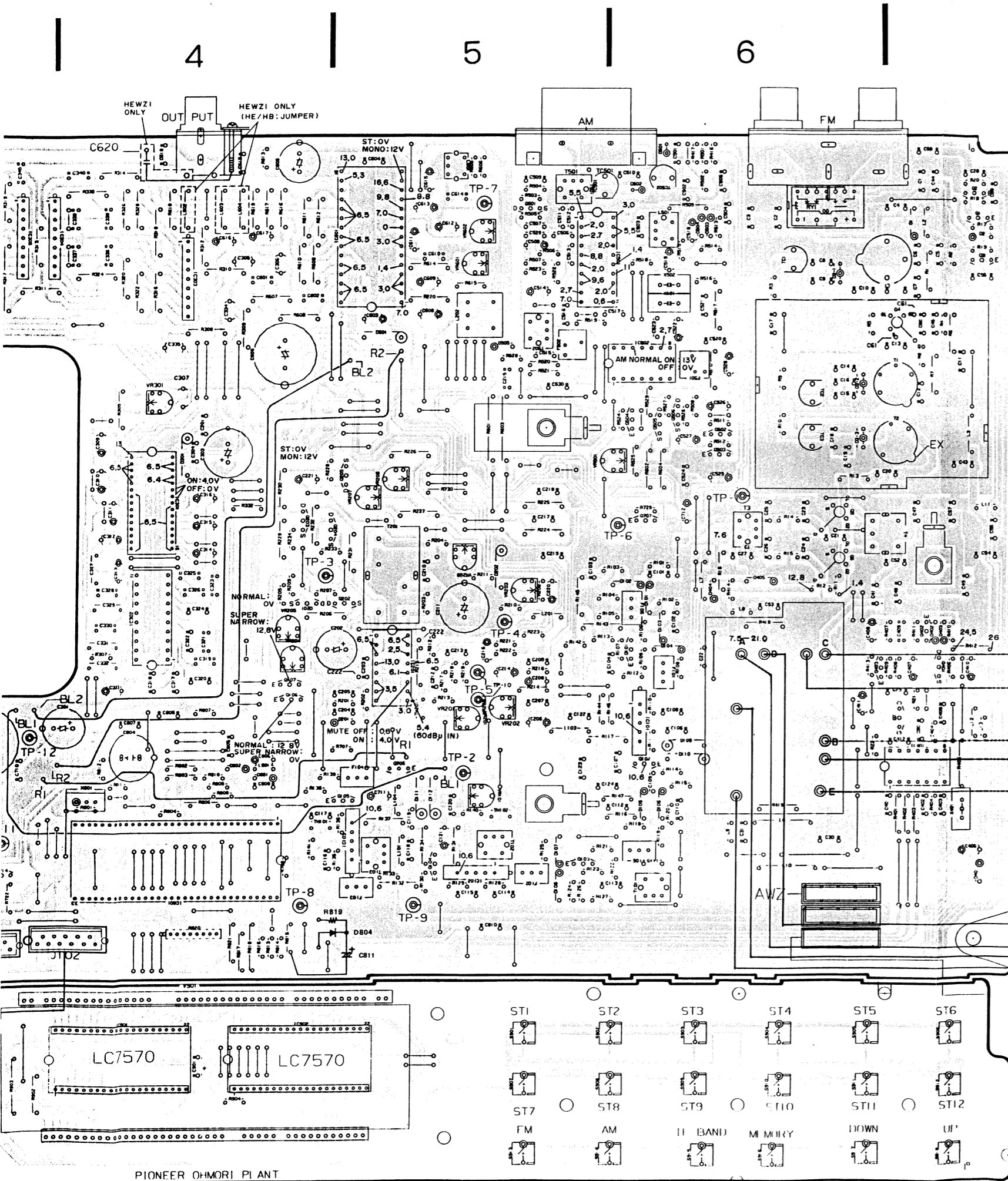

TC501	Q2
TC502	Q1
VR602	IC601
TC1	IC306 IC305 IC304
VR601	IC501 Q3
	IC303
	Q4
	IC502
TC2	Q506
VR301	Q504 Q505
TC3	Q502
VR501	Q503
VR206	Q205
VR207	IC301 Q707 Q5
	Q203 Q204
VR208	Q6
VR203	Q201 Q202
VR205	IC302 Q402
	Q101
VR204	IC201 Q403 Q401
VR201	Q107
VR202	Q106 IC101 Q7
	IC701
VR101	Q706 Q102 IC401
	Q105
	TH201 TH101
	Q801 Q702 IC103 Q103
	IC801 Q104 IC102
	Q715 Q712 Q701 Q703 Q714
	Q716 Q711 Q704 Q705 Q802
	Q708 Q710 Q709
IC901	IC902
Q901	

NOTE

1. This P.C.B connection diagram is viewed from the parts mounted side.
2. The parts which have been mounted on the board can be replaced with those shown with the corresponding wiring symbols listed in the following Table.

P.C.B. pattern diagram indication	Corresponding part symbol	Part Name
		Transistor
		Radiator type transistor
		Diode
		Resistor
		Capacitor (Polarity)
		Capacitor (Non-polarity)

3. The capacitor terminal marked with ⊙ (double circles) shows negative terminal.
4. The diode terminal marked with ⊙ (double circles) shows cathode side.
5. The transistor terminal to which E is affixed shows the emitter.

* 1; Specifications for D3-1 to D3-4 are matched. If you change D3-1 to D3-3, at the same time also change FM VCO assembly. Likewise, if you change FM VCO assembly, at the same time change D3-1 to D3-3. In the case of both of the above mentioned, D3-1 to D3-3 parts are mounted on the newly ordered FM VCO assembly; use spare parts.

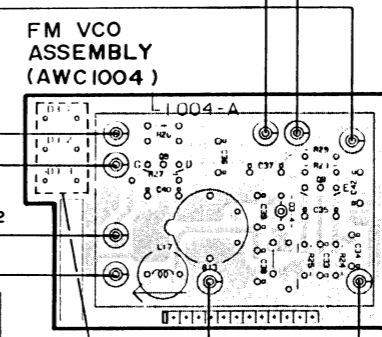

Tuner assembly spare parts at changing FM VCO assembly.

5. P.C.B'S PARTS LIST

NOTES:

- Parts without part number cannot be supplied.
- Parts marked by "⊙" are not always kept in stock. Their delivery time may be longer than usual or they may be unavailable.
- The Δ mark found on some component parts indicates the importance of the safety factor of the part. Therefore, when replacing, be sure to use parts of identical designation.
- When ordering resistors, first convert resistance values into code form as shown in the following examples.

Ex.1 When there are 2 effective digits (any digit apart from 0), such as 560 ohm and 47k ohm (tolerance is shown by J = 5%, and K = 10%)

560Ω	56 × 10 ¹	561.....	RD1/4PS	5	6	1	J
47kΩ	47 × 10 ³	473.....	RD1/4PS	4	7	3	J
0.5Ω	0R5.....		RN2H	0	R	5	K
1Ω	010.....		RS1P	0	1	0	K

Ex.2 When there are 3 effective digits (such as in high precision metal film resistors).

5.62kΩ	562 × 10 ¹	5621.....	RN1/4SR	5	6	2	1	F
--------	-----------------------	-----------	---------	---	---	---	---	---

Mark	Symbol & Description	Part No.	Mark	Symbol & Description	Part No.
TUNER ASSEMBLY (AWZ2904)					
SEMICONDUCTORS					
	IC101-103 IC	TA7060AP		Q706 TRANSISTOR	2SB560
	IC201 FM IC	PA5008		Q707 TRANSISTOR	2SA1115
	IC301 FM-NR	PA0042		Q708 TRANSISTOR	2SB834
	IC302 GEQ IC	LA3607		Q709-712 TRANSISTOR	2SC2878
	IC303-306 OP-AMP IC	UPC4570HA		Q713 TRANSISTOR	DTA143ES
	IC401 IC	CX-7925B		Q714 TRANSISTOR	DTC124ES
	IC501 AM IC	LA1247		Q715, 716 TRANSISTOR	2SC2603
	IC502 LOGIC IC	UPD4066BC		Q801 TRANSISTOR	DTC124ES
	IC601 MPX IC	PA5007		Q802 TRANSISTOR	DTA143ES
	IC701 REGULATOR IC	UPC78M05H		D1 DIODE	1SV156
	IC801 TUNER CONTROL	PD5132		D2 DIODE	1SS252
	Q1 TRANSISTOR	2SC2705		D101-108 DIODE	1SS85
	Q2 TRANSISTOR	2SC2603		D109-112 DIODE	2-1K251
	Q3 TRANSISTOR	DTA143ES		D201 DIODE	1SS252
	Q4-6 FET	3SK122		D202 ZENER DIODE	RD8.2FB
	Q7 N-FET	2SK161		D301 ZENER DIODE	RD8.2FB
	Q101-105 TRANSISTOR	2SC2668		D3-1 VARI-CAP DIODE	* 1
	Q106, 107 TRANSISTOR	DTA143ES		D3-2 VARI-CAP DIODE	* 1
	Q201, 202 N-FET	2SK246		D3-3 VARI-CAP DIODE	* 1
	Q203-205 N-FET	2SK117		D401-404 DIODE	1SS252
	Q401 N-FET	2SK246		D405 ZENER DIODE	RD7.5EB
	Q402 TRANSISTOR	2SA1115		D501, 502 VARI-CAP DIODE	SVC321 C2
	Q403 TRANSISTOR	2SC2603		D503 DIODE	1SS252
	Q501 N-FET	2SK246		D504 ZENER DIODE	RD5.1ESB
	Q502 TRANSISTOR	2SA1115		D505 DIODE	1SS252
	Q503 TRANSISTOR	2SC2603		D601 ZENER DIODE	RD8.2FB
	Q504 TRANSISTOR	DTA124ES		D701-706 DIODE	10DF2FD
	Q505, 506 N-FET	2SK246		D707-710 DIODE	S5566
	Q701 N-FET	2SK246		D711, 712 ZENER DIODE	RD135B
	Q702 TRANSISTOR	2SB834		D713, 714 ZENER DIODE	HZS93L
	Q703, 704 TRANSISTOR	2SC2603		D715 ZENER DIODE	HZS62L
	Q705 TRANSISTOR	DTC143ES		D716 DIODE	1SS252
				D717 ZENER DIODE	HZS93L
				D718 DIODE	1SS252
				D719 ZENER DIODE	RD8.25B

* 1; Specifications for D3-1 to D3-4 are matched. If you change D3-1 to D3-3, at the same time also change FM VCO assembly. Likewise, if you change FM VCO assembly, at the same time change D3-1 to D3-3. In the case of both of the above mentioned, D3-1 to D3-3 parts are mounted on the newly ordered FM VCO assembly; use spare parts.

Mark	Symbol & Description	Part No.	Mark	Symbol & Description	Part No.
	D720 ZENER DIODE	RD2.2ESB		C21 CERAMIC CAPACITOR	CCDCH030C50
	D801, 802, 804 DIODE	1SS252		C22 CAPACITOR(0.022 μ F)	ACG1022
	D803 ZENER DIODE	RD6.2ESB2		C23, 24 CERAMIC CAPACITOR	CCDCH030C50
	TH101 THERMISTOR	TH103-2		C25, 26 CERAMIC CAPACITOR	CCDCH101J50
	TH102 THERMISTOR	NTH5D104KA		C27 CERAMIC CAPACITOR	CKDYX473M25
	TH201 THERMISTOR	TH103-2		C28 CERAMIC CAPACITOR	CKDYF473Z50
RELAIRES				C29, 30 CERAMIC CAPACITOR	CKDYX103M25
	RY1 RELAY	ASR-087		C31 CERAMIC CAPACITOR	CKDYX473M25
COILS, TRANSFORMERS AND FILTERS				C41 CERAMIC CAPACITOR	CKDYX103M25
	L1 COIL	ATC-244		C43 CERAMIC CAPACITOR	CKDYX103M25
	L2 AXIAL INDUCTOR	LAU100K		C44 CERAMIC CAPACITOR	CKDYF103Z50
	L3 AXIAL INDUCTOR	LAU2R2M		C45 CERAMIC CAPACITOR	CKDYX103M25
	L6, 9 AXIAL INDUCTOR	LAU2R2M		C47-49 CERAMIC CAPACITOR	CKDYX103M25
	L11, 13 AXIAL INDUCTOR	LAU2R2M		C50 CERAMIC CAPACITOR	CCDCH150J50
	L7, 8, 10, 12 AXIAL INDUCTOR	LAU010M		C52-60 CERAMIC CAPACITOR	CKDYX473M25
	L101 AXIAL INDUCTOR	LAU2R2M		C61 CERAMIC CAPACITOR	CKDYX473M25
	L103, 104 AXIAL INDUCTOR	LAU2R2M		C101 CERAMIC CAPACITOR	CKDYF103Z50
	L201 AXIAL INDUCTOR	LAU2R2M		C102-104 CERAMIC CAPACITOR	CKDYX473M25
	L202 COIL	ATM-028		C106 CERAMIC CAPACITOR	CKDYF103Z50
	L501 COIL	ATB-073		C107, 108 CERAMIC CAPACITOR	CKDYX473M25
	L601 COIL	ATM-026		C109 CAPACITOR(0.01 μ F)	ACG1021
	L602 AXIAL INDUCTOR	LAU100K		C110 CERAMIC CAPACITOR	CKDYX473M25
	L603 AXIAL INDUCTOR	LAU010M		C111 CAPACITOR(0.01 μ F)	ACG1021
	L604 AXIAL INDUCTOR	LAU100K		C112-118 CERAMIC CAPACITOR	CKDYX473M25
	L801 AXIAL INDUCTOR	LAU220K		C119 CAPACITOR(0.01 μ F)	ACG1021
	T1 COIL	ATC-204		C120 CERAMIC CAPACITOR	CKDYX473M25
	T2 COIL	ATC-257		C121 ELECTR.CAPACITOR	CEAS010M50
	T3 IF TRANSFORMER	ATE-066		C122 CERAMIC CAPACITOR	CKDYX473M25
	T4 RF TRANSFORMER	ATC-218		C123, 124 CERAMIC CAPACITOR	CKDYX103M25
	T101-103 FM TRANSFORMER	ATE-063		C201 CERAMIC CAPACITOR	ACG-038
	T201 IF TRANSFORMER	ATE-068		C202 ELECTR.CAPACITOR	CEEA102M16
	T501 COIL	ATB-087		C203 CERAMIC CAPACITOR	ACG-038
	T502 IF TRANSFORMER	ATB1002		C204, 205 CERAMIC CAPACITOR	CKDYX473M25
	F101-104 CERAMIC FILTER	ATF1080		C206 ELECTR.CAPACITOR	CEAS010M50
	F105, 106 CERAMIC FILTER	ATF1079		C207 CERAMIC CAPACITOR	CKDYF223Z50
	F501 CERAMIC FILTER	ATF1004		C208 ELECTR.CAPACITOR	CEAS010M50
	F502 CERAMIC FILTER	ATF1077		C209 CERAMIC CAPACITOR	CKDYF223Z50
CAPACITORS				C210 CERAMIC CAPACITOR	ACG-038
	TC1-3 CERAMIC TRIMMER	ACM-018		C211 ELECTR.CAPACITOR	CEEA222M16
	TC501, 502 CERAMIC TRIMMER	ACM-019		C212, 213 CERAMIC CAPACITOR	CCDSL181J50
	C1-3 CERAMIC CAPACITOR	CKDYF103Z50		C214 ELECTR.CAPACITOR	CEAS4R7M50
	C4 CERAMIC CAPACITOR	CKDYX103M25		C215 CAPACITOR	CQSA821J50
	C5 CERAMIC CAPACITOR	CKDYF103Z50		C216 ELECTR.CAPACITOR	CEEA220M25
	C6, 7 CERAMIC CAPACITOR	CCDCH150J50		C217 CERAMIC CAPACITOR	CCDCH150J50
	C8, 9 CERAMIC CAPACITOR	CCDSH030C50		C218 CERAMIC CAPACITOR	CCDCH330J50
	C10 CERAMIC CAPACITOR	CCDCH050C50		C219 CERAMIC CAPACITOR	ACG-038
	C11 CERAMIC CAPACITOR	CKDYX473M25		C220 ELECTR.CAPACITOR	CEEA010M50
	C12 CERAMIC CAPACITOR	CKDYX103M25		C221 ELECTR.CAPACITOR	CEAS010M50
	C13 CERAMIC CAPACITOR	CCDCH030C50		C222 CERAMIC CAPACITOR	ACG-038
	C14, 15 CERAMIC CAPACITOR	CCDSH100D50		C301 ELECTR.CAPACITOR	CEEA102M16
	C16 CERAMIC CAPACITOR	CCDSH820J50		C303 ELECTR.CAPACITOR	CEEA222M16
	C17 CERAMIC CAPACITOR	CKDYF103Z50		C304 CERAMIC CAPACITOR	ACG-038
	C18, 19 CERAMIC CAPACITOR	CCDSH100D50			
	C20 CERAMIC CAPACITOR	CKDYX103M25			

Mark	Symbol & Description	Part No.	Mark	Symbol & Description	Part No.
C305, 306	ELECTR. CAPACITOR	CEEANP010M50	C511	CAPACITOR(1000p/50)	ACG1020
C307	ELECTR. CAPACITOR	CEEANP100M25	C512	CAPACITOR(0.022 μ F)	ACG1022
C309	ELECTR. CAPACITOR	CEAS4R7M50	C513	CAPACITOR(0.01 μ F)	ACG1021
C310	ELECTR. CAPACITOR	CEAS2R2M50	C514	ELECTR. CAPACITOR	CEAS330M16
C311	ELECTR. CAPACITOR	CEAS1R5M50	C515	CAPACITOR(0.01 μ F)	ACG1021
C312	ELECTR. CAPACITOR	CEAS010M50	C516	CERAMIC CAPACITOR	CKDYF223Z50
C313	ELECTR. CAPACITOR	CEASR68M50	C517	CAPACITOR(1000p/50)	ACG1020
C314	ELECTR. CAPACITOR	CEASR47M50	C518, 519	ELECTR. CAPACITOR	CEAS4R7M50
C315	ELECTR. CAPACITOR	CEASR22M50	C520	MYLOR FILM CAPACITOR	CQMA393J50
C316	ELECTR. CAPACITOR	CEASR15M50	C521	MYLOR FILM CAPACITOR	CQMA103J50
C317	CAPACITOR	CQMXA472J100	C522	ELECTR. CAPACITOR	CEAS330M16
C318	CAPACITOR	CQMXA152J100	C523	CAPACITOR(0.022 μ F)	ACG1022
C319	CAPACITOR	CQMXA822J100	C524	CERAMIC CAPACITOR	CKDYF223Z50
C320	CAPACITOR	CQMXA222J100	C525, 526	ELECTR. CAPACITOR	CEAS010M50
C321	CAPACITOR	CQMXA123J100	C527	ELECTR. CAPACITOR	CEAS330M16
C322	CAPACITOR	CQMXA392J100	C528	ELECTR. CAPACITOR	CEAS0R1M50
C323	CAPACITOR	CQMXA223J100	C529	CAPACITOR(0.022 μ F)	ACG1022
C324	CAPACITOR	CQMXA562J100	C530	CERAMIC CAPACITOR	CKDYX103M25
C325	CAPACITOR	CQMXA333J100	C601, 602	CAPACITOR	CQSA152J160
C326	CAPACITOR	CQMXA103J100	C603	ELECTR. CAPACITOR	CEEA470M25
C327	CAPACITOR	CQMXA563J100	C604	CERAMIC CAPACITOR	ACG-038
C328	CAPACITOR	CQMXA153J100	C605	ELECTR. CAPACITOR	CEEA222M25
C329	CAPACITOR	CQMXA823J100	C606	ELECTR. CAPACITOR	CEEA102M16
C330	CAPACITOR	CQMXA273J100	C608	ELECTR. CAPACITOR	CEAS100M25
C331	CAPACITOR	CQMXA104J100	C609	ELECTR. CAPACITOR	CEAS1R5M50
C332	CAPACITOR	CQMXA563J100	C610	CERAMIC CAPACITOR	ACG-023
C333	ELECTR. CAPACITOR	CEEA220M25	C611	ELECTR. CAPACITOR	CEAS6R8M50
C334, 335	ELECTR. CAPACITOR	CEEANP4R7M25	C612, 613	ELECTR. CAPACITOR	CEAS100M25
C336, 337	CAPACITOR	CQSA103J50	C614	PL. PROPYENE CAPACIT	CQPA682G100
C338-340	CAPACITOR	CQMXA103J100	C615	ELECTR. CAPACITOR	CEAS220M25
C341, 342	CAPACITOR	CQSA103J50	C616, 617	ELECTR. CAPACITOR	CEEA100M25
C343-345	CAPACITOR	CQMXA103J100	C618, 619	CAPACITOR	CQMXA822J100
C401	CERAMIC CAPACITOR	CKDYF103Z50	C620	CERAMIC CAPACITOR	CKDYX473M25
C402	CERAMIC CAPACITOR	CCDCH150J50	C702	ELECTR. CAPACITOR	CEAS470M35
C403	CERAMIC CAPACITOR	CCDCH180J50	C703	ELECTR. CAPACITOR	CEAS221M63
C404	CAPACITOR(0.01 μ F)	ACG1021	C704	ELECTR. CAPACITOR	CEAS221M50
C405	CERAMIC CAPACITOR	CKDYX473M25	C705	ELECTR. CAPACITOR	CEAS471M50
C406	ELECTR. CAPACITOR	CEAS101M10	C706	ELECTR. CAPACITOR	CEEA332M35
C407	ELECTR. CAPACITOR	CEAS470M25	C707	CERAMIC CAPACITOR	ACG-038
C408	ELECTR. CAPACITOR	CEANLR47M50	C708	ELECTR. CAPACITOR	CEEA101M16
C409	CAPACITOR	CQMXA103J100	C709	ELECTR. CAPACITOR	CEEA101M25
C410	ELECTR. CAPACITOR	CEAS101M35	C710	CERAMIC CAPACITOR	ACG-038
C411	ELECTR. CAPACITOR	CEEA2R2M50	C711	ELECTR. CAPACITOR	CEEA101M25
C412	CERAMIC CAPACITOR	CKDYX473M25	C712	ELECTR. CAPACITOR	CEAS101M25
C501	CERAMIC CAPACITOR	CCDUJ100D50	C713	ELECTR. CAPACITOR	CEAS222M25
C502	CAPACITOR	CQSA471J50	C714, 715	ELECTR. CAPACITOR	CEAS101M16
C503	CERAMIC CAPACITOR	CKDYX223M25	C716	ELECTR. CAPACITOR	CEAS471M25
C504	CERAMIC CAPACITOR	CKDYF103Z50	C717	ELECTR. CAPACITOR	CEAS470M25
C505	CERAMIC CAPACITOR	CCDSL101J50	C718	ELECTR. CAPACITOR	CEAS101M16
C506	CAPACITOR(0.01 μ F)	ACG1021	C720	ELECTR. CAPACITOR	CEAS220M25
C507	CAPACITOR(0.022 μ F)	ACG1022	C721	ELECTR. CAPACITOR	CEAS100M50
C508	ELECTR. CAPACITOR	CEAS100M50	C722	CERAMIC CAPACITOR	CKDYF223Z50
C509	CERAMIC CAPACITOR	CKDYF103Z50	C801	CERAMIC CAPACITOR	CCDS101J50
C510	CERAMIC CAPACITOR	CKDYX223M25	C802	ELECTR. CAPACITOR	CEAS100M25
			C803	CERAMIC CAPACITOR	CCDS101J50

Mark	Symbol & Description	Part No.
C804	CAPACITOR	ACH1037
C805	CERAMIC CAPACITOR	CKDYF223Z50
C806	ELECTR. CAPACITOR	CEAS470M10
C807, 808	CERAMIC CAPACITOR	CKDYF103Z50
C809	CERAMIC CAPACITOR	CKDYF223Z50
C811	ELECTR. CAPACITOR	CEAS010M50
C810	CERAMIC CAPACITOR	CKDYX473M25
RESISTORS		
VR101	VR	VRTB6VS474
VR201	VR	VRTB6VS103
VR202	VR(220k)	ACP1029
VR203	VR	VRTB6VS221
VR204	VR(22k)	ACP1026
VR205	VR(10k)	ACP1025
VR206, 207	VR(22k)	ACP1026
VR208	VR	VRTB6VS102
VR301	VR	VRTB6VS473
VR501	VR(47k)	ACP1027
VR601	VR	VRTS6VS222
VR602	VR(22k)	ACP1026
R1	CARBONFILM RESISTOR	RD1/4PM□□□J
R7	CARBONFILM RESISTOR	RD1/4PM□□□J
R16	CARBONFILM RESISTOR	RD1/4PM□□□J
R117	CARBONFILM RESISTOR	RD1/4PM□□□J
R131	CARBONFILM RESISTOR	RD1/4PM□□□J
R137	CARBONFILM RESISTOR	RD1/4PM□□□J
R143	CARBONFILM RESISTOR	RD1/4PM□□□J
R145	CARBONFILM RESISTOR	RD1/4PM□□□J
R206	CARBON FILM RESISTOR	RDR1/4PM□□□J
R224-227	CARBON FILM RESISTOR	RDR1/4PM□□□J
R229-232	CARBON FILM RESISTOR	RDR1/4PM□□□J
R305	CARBON FILM RESISTOR	RDR1/4PM□□□J
R308-331	CARBON FILM RESISTOR	RDR1/4PM□□□J
R418 - 420	CARBON FILM RESISTOR	RDR1/4PM□□□J
R510	CARBONFILM RESISTOR	RD1/4PM□□□J
R517	CARBON FILM RESISTOR	RDR1/4PM□□□J
R601-604	CARBON FILM RESISTOR	RDR1/4PM□□□J
R607-612	CARBON FILM RESISTOR	RDR1/4PM□□□J
R614	METALFILM RESISTER	RN1/4PQ5601F
R616-619	CARBON FILM RESISTOR	RDR1/4PM□□□J
R701, 702	CARBONFILM RESISTOR	RD1/2PM471J
R703	CARBONFILM RESISTOR	RD1/4PM□□□J
R709	CARBONFILM RESISTOR	RD1/4PM□□□J
R710	METAL OXIDE RESISTOR	RS2LMF2R2J
R712	CARBONFILM RESISTOR	RD1/2PM101J
R713-716	CARBONFILM RESISTOR	RD1/4PM□□□J
R820	RESISTOR ARRAY (22k)	RA7T223J

Mark	Symbol & Description	Part No.
	OTHER RESISTORS (22k)	RD1/8PM□□□J
OTHERS		
X401	RESISTOR(7.200MHz)	ASS1005
X501, 502	CERAMIC RESONATOR	ATF1027
X801	RESONATOR(4.19MHz)	ASS1018
	PIN JACK (2p)	AKB1039
	TERMINAL 2-P	AKE-060
	SOCKET	AKX1034
	FM VCO ASSEMBLY	AWC1004

FM VCO ASSEMBLY (AWC1004)

- This assembly comprises internal parts for tuner assembly.
- There are no service supplied parts for this assembly.

DISPLAY ASSEMBLY (AWZ2933)

SEMICONDUCTORS

IC901, 902 FL STATIC DRIVER IC LC7570

Q901 TRANSISTOR DTC143ES

D901-905 DIODE 1SS252
D906, 907 LED AEL1072

SWITCHES

S901-924 TACT SWITCH ASG1029

CAPACITOR

C901 CAPACITOR(0.022μF) ACG1022

RESISTORS

R902 CARBONFILM RESISTOR RD1/4PM151J
OTHER RESISTORS RD1/8PM□□□J

OTHER

V901 FL TUBE AAV1095

6. ADJUSTMENTS

PREPARATIONS

- Short TP8 and TP 9 (GND), then remove that short.
- Set TC1 – TC3 and VR202 to their mechanical centers.

FM tuner adjustment

- Connect as shown in Fig. 6-1.
- Set the function to FM.

Step No.	Adjustment	FM SG (1 kHz \pm 75 kHz dev.)			F-757 reception frequency display	Adjustment	
		Frequency (MHz)	Modulation	Level (dB μ V)		Location	Specification
1	Front-end VT adjustment	NO INPUT SIGNAL			108MHz NORMAL or SUPER NARROW	L18	Adjust so that the voltage between TP1 and ground is 21.0 \pm 0.1 V.
2					87.5 MHz NORMAL or SUPER NARROW	–	Confirm that the voltage between TP1 and ground is 7.6 \pm 0.5 V.
3	Front-end sensitivity-up adjustment	90.0	MONO	Weak input	90.0 MHz NORMAL	L1, T1, T2	Adjust for the maximum voltage between TP10 and ground. Repeat these two steps until both specifications are satisfied. (*1)
4		106.0	MONO	Weak input	106.0 MHz NORMAL	TC1 – TC3	
5	IF stage sensitivity-up adjustment	98.0	MONO	Weak input	98.0 MHz SUPER NARROW	T3, T101 – T103	Adjust so that voltage between TP10 and ground becomes maximum.
6	Detector VT adjustment	98.0	MONO	60	98.0 MHz NORMAL	T201-B	After setting the voltage between TP4 and TP5 to 0 \pm 100 mV, check that the modulated signals are output from the output terminal.
7	Monaural distortion adjustment (NORMAL)	98.0	MONO	60	98.0 MHz NORMAL	T102-A VR208	Adjust so as to minimize (0.3% or less) distortion. If this cannot be achieved, turn T201-B, voltage between TP4 and TP5 within 0 \pm 100 mV, then repeat the above adjustment.
8	SUB balance adjustment	98.0	MONO	60	98.0 MHz NORMAL	VR203	Adjust to minimize the output at TP3. (AC voltage)
9	VCO adjustment	108	OFF	60	108.0 MHz NORMAL or SUPER NARROW	VR601	Adjust so that the output at TP7 is 38 kHz \pm 100 Hz
10	Pilot cancel adjustment	107 (*2)	PILOT ONLY	60	107 MHz NORMAL	VR602	Adjust so as to minimize the output terminal AC voltage.
11	Stereo distortion adjustment (NORMAL)	89 (*2)	L-ONLY	60	89 MHz NORMAL	VR204	Adjust so as to minimize (0.3% or less) distortion. If this cannot be achieved, try turning T3, T102 and T103 within \pm 90°.
12	Stereo distortion adjustment (SUPER NARROW)	89.0 (*2)	L-ONLY	60	89.0 MHz SUPER NARROW	VR205 T101	Adjust so as to minimize (2.0% or less) distortion. If this cannot be achieved, try turning T3, T102 and T103 within \pm 90° (check step 11 after this).
13	Stereo distortion fine adjustment	If readings in steps 11 and 12 do not fully satisfy adjustment specifications, fine adjust by turning L202 within \pm 45°.					
14	Separation adjustment	89 (*2)	R-ONLY	60	89 MHz NORMAL	VR206	Adjust for the maximum R \rightarrow L separation.
15		89 (*2)	L-ONLY	60	89 MHz NORMAL	VR207	Adjust for the maximum L \rightarrow R separation.

Step No.	Adjustment	FM SG (1 kHz \pm 75 kHz dev.)			F-757 reception frequency display	Adjustment	
		Frequency (MHz)	Modulation	Level (dB μ V)		Location	Specification
16	Noise reduction separation adjustment	89 (*2)	STEREO	60	89 MHz NORMAL MPX NR ON	VR301	After turning VR301 fully counterclockwise, turn it gradually clockwise until separation becomes 20 dB \pm 1 dB.
17	S meter adjustment	89	MONO	45	89.0 MHz NORMAL	VR202	Adjust so that voltage between TP2 and ground becomes 5.0 \pm 0.05 V.
18				75		VR101	Adjust so that voltage between TP2 and ground becomes 1.6 \pm 0.05 V.
19	Muting level adjustment	99	MONO	12	99.0 MHz NORMAL	VR201	Adjust so that muting is cancelled (and the signal is delivered through the output terminal) at 12 dB μ .

(*1) The adjustments for the HEWZI model end with Step 4.

(*2) Stereo modulation: Main 1 kHz L + R \pm 68.25 Hz
Pilot 19 kHz \pm 6.75 kHz

AM tuner adjustment

- Connect as shown in Fig. 6-2.
- Set TC501 and TC502 to their mechanical centers.
- Steps 1 and 2 should be carried out in the SUPER NARROW or NORMAL mode, and steps 3 to 6 in the SUPER NARROW mode.

Step No.	Adjustment	AM SG (400 kHz 30% modulation)		F-757 reception frequency display	Adjustment	
		Frequency (kHz)	Level (dB μ V/m)		Location	Specification
1	Front-end VT adjustment	NO INPUT SIGNAL		531 kHz	L501	Adjust so that the voltage between TP1 and ground is 2.0 \pm 0.2 V.
2				1602 kHz	TC502	Adjust so that the voltage between TP1 and ground is 16.0 \pm 0.2 V.
3	Front-end sensitivity-up adjustment	603	Weak input	603 kHz	T501	Adjust so as to maximize the voltage between TP6 and ground.
4		1395	Weak input	1395 kHz	TC501	
5	Repeat steps 3 and 4 until optimum adjustment is obtained.					
6	S meter adjustment	999	100	999 kHz	VR501	Adjust so that the voltage between TP6 and ground is 5.0 \pm 0.1 V.

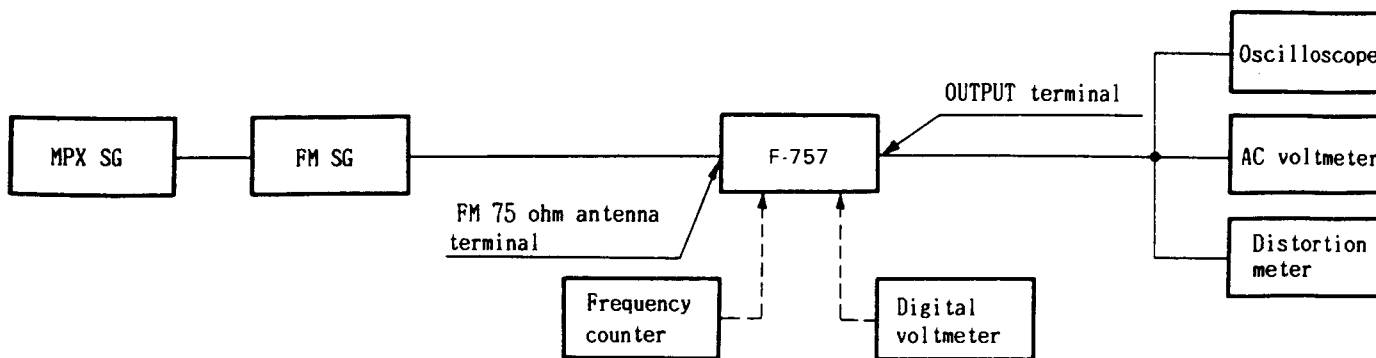

Fig. 6-1 FM Tuner Connection

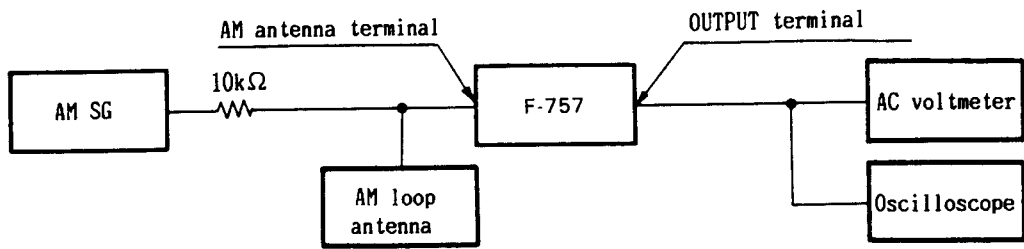

Fig. 6-2 AM Tuner Connection

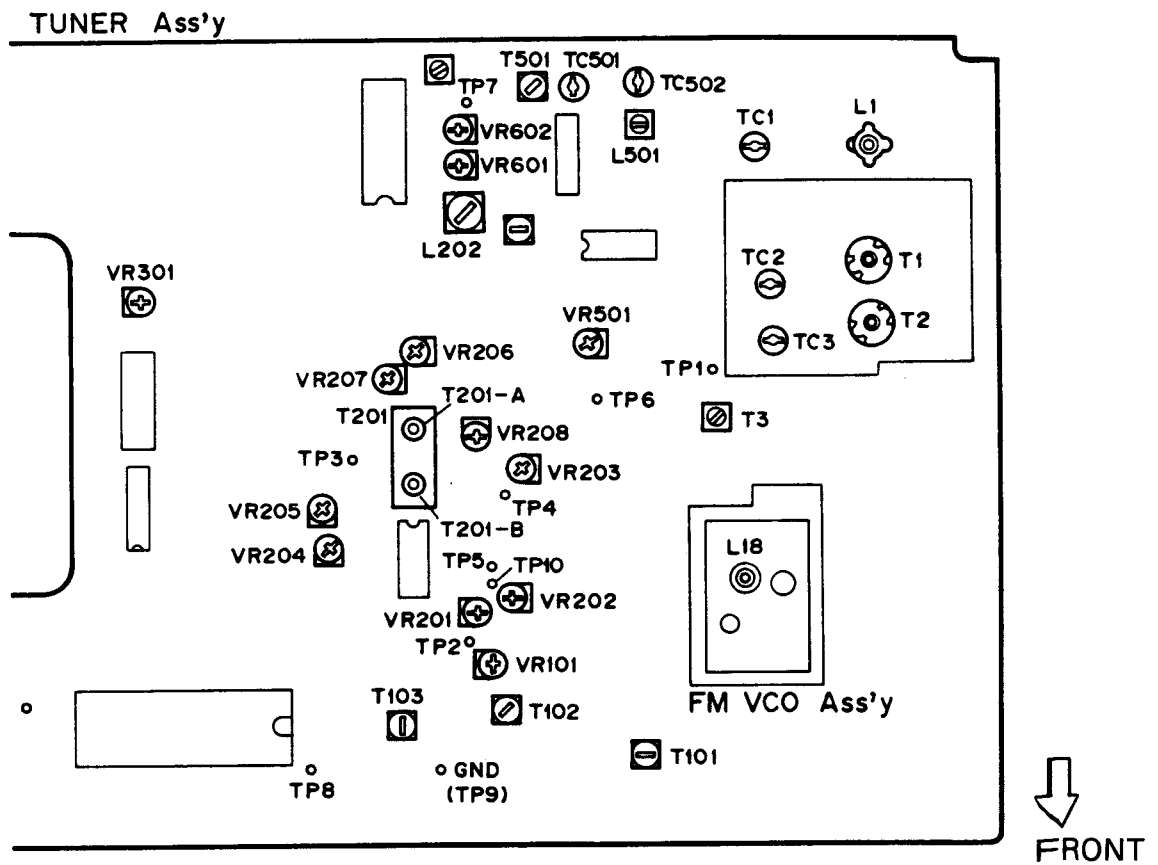

Fig. 6-3 Adjusting point

7. IC INFORMATION

PD5132 Terminal Functions

No.	Pin Name	I/O	Function	Active
1	Vcc	—	+5V power supply	—
2	GND	—	A/D ground	—
3	VREF	I	A/D reference voltage input	H/L
4	D-A	—	NC	—
5	—	—	NC	—
6	MONO	O	MONO	H
7	MUTE	O	MUTE	H
8	NR	O	N.R.	H
9	SS	O	S.STEREO (SSS)	H
10	S ADD	I	FM S meter addition	H/L
11	MUTE	I	O-VOLT MUTE	H/L
12	AM SM	I	AM S meter	H/L
13	FM SM	I	FM S meter	H/L
14	9K/10K	I	9/10 kHz recognition input (H: 9 kHz, L: 10 kHz)	H/L
15	ST	I	Stereo data	L
16	J/E	I	Japan/other countries recognition input (H: Japan, L: other countries)	H/L
17	—	O	NC (GND)	—
18	—	O	NC (GND)	—
19	—	O	NC (GND)	—
20	—	O	NC (GND)	—
21	—	O	NC (GND)	—
22	RF ATT	O	RF ATT	H
23	INT	I	AC input	L
24	REM	I	Remote control input	L
25	LED	O	Power IND	L
26	INT	—	Not used; 5-V pull-up	—
27	GND	—	Ground	—
28	RES	I	Power supply input	L
29	XI	I	4.2 MHz oscillator connection	—
30	XO	O	4.2 MHz oscillator connection	—
31	∅	—	NC	—
32	Vss	—	Ground	—
33	—	—	NC (GND)	—
34	K11	I	Key matrix input	L
35	K12	I	Key matrix input	L
36	K13	I	Key Matrix input	L
37	K14	I	Key matrix input	L
38	K15	I	Key matrix input	L
39	K16	I	Key matrix input	L
40	K17	I	Key matrix input	L

No.	Pin Name	I/O	Function	Active
41	—	—	NC (GND)	—
42	—	—	NC (GND)	—
43	FM + B	O	FM + B	L
44	NARROW	O	Narrow	L
45	WIDE	O	Wide	L
46	AM + B	O	AM + B	L
47	FLAC	O	FL AC	L
48	SB	O	Super base	H
49	PMT	O	Power mute	H
50	PWR	O	Power	L
51	TEST	I	Test data	L
52	ANT A/B	O	ANT-A/B change	H/L
53	K04	O	Key matrix output	L
54	K03	O	Key matrix output	L
55	K02	O	Key matrix output	L
56	K01	O	Key matrix output	L
57	—	—	NC (GND)	—
58	PLL	—	PLL	—
59	BLK	O	FL blank	L
60	ST1	O	LC7570 No.1 enable	H
61	ST2	O	LC7570 No.2 enable	H
62	PLL E	O	PLL enable	H
63	DAT	O	Serial transfer data	H
64	CLK	O	Serial transfer data	H

PA0042

No.	Pin Name	Function
1	Vcc	Power supply
2	CH1 IN	CH1 input
3	CH2 IN	CH2 input
4	OUT	Output for control
5	IN	Input for control
6	SB	Low-range emphasis
7	C1	DC capacitor 1
8	F1	Band-pass filter 1
9	C2	DC capacitor 2
10	F2	Band-pass filter 2
11	C3	DC capacitor 3
12	F3	Band-pass filter 3
13	C4	DC capacitor 4
14	F4	Band-pass filter 4
15	C5	DC capacitor 5
16	F5	Band-pass filter 5
17	C6	DC capacitor 6
18	F6	Band-pass filter 6
19	C7	DC capacitor 7
20	F7	Band-pass filter 7
21	C8	DC capacitor 8
22	F8	Band-pass filter 8
23	S3	Mode selection 3
24	S2	Mode selection 2
25	S1	Mode selection 1
26	REF	Reference voltage input
27	VREF	Internal reference voltage terminal
28	CH2 OUT	CH2 output
29	CH1 OUT	CH1 output
30	GND	Ground

8. FOR HE AND HB TYPES

NOTES:

- Parts without part number cannot be supplied.
- Parts marked by "⊙" are not always kept in stock. Their delivery time may be longer than usual or they may be unavailable.
- The Δ mark found on some component parts indicates the importance of the safety factor of the part. Therefore, when replacing, be sure to use parts of identical designation.

CONTRAST OF MISCELLANEOUS PARTS

F-757/HE and HB types are the same as the F-757/HEWZI type with the exception of the following sections.

Mark	Symbol & Description	Part No.			Remarks
		F-757/HEWZI	F-757/HE	F-757/HB	
Δ	Tuner assembly	AWZ2904	AWZ2932	AWZ2932	
	AC power cord	ADG1010	ADG1021	ADG-063	
	GND screw	ABA1047	—	—	
	Name plate	Non supply	Non supply	Non supply	
	Shield plate	Non supply	—	—	
	Operating instructions (German, Italian)	ARC1179	—	—	
	Operating instructions (English)	—	ARE1140	—	
	Operating instructions (English/French/German/Italian /Dutch/Swedish/Spanish/Portuguese)	—	—	ARB1224	

Tuner Assembly (AWZ2932)

The Tuner assembly (AWZ2932) is the same as the Tuner assembly (AWZ2904) with the exception of the following sections.

Mark	Symbol & Description	Part No.		Remarks
		AWZ2904	AWZ2932	
	L602, L604	LAU100K	—	
	L603	LAU010M	—	
	C620	CKDYX473M25	—	
	R611, R612	RDR1/4PM103J	RDR1/4PM102J	
	R616, R617	RDR1/4PM471J	RDR1/4PM102J	

9. SPECIFICATIONS

FM Tuner Section

Frequency range	87.5 MHz to 108 MHz
Usable Sensitivity	
NORMAL	Mono: 11.2 dBf, IHF (1.0 μ V/75 Ω)
50 dB Quieting Sensitivity	
NORMAL	Mono: 15.9 dBf, IHF (1.7 μ V/75 Ω)
	Stereo: 36.2 dBf, IHF (17.7 μ V/75 Ω)
Sensitivity (DIN)	
NORMAL	Mono: 0.8 μ V/75 Ω
	Stereo: 26 μ V/75 Ω
Signal-to-Noise Ratio	Mono: 94 dB (at 80 dBf)
	Stereo: 87 dB (at 80 dBf)
Distortion (at 80 dBf)	
NORMAL	Mono: 0.03 % (1 kHz)
	Stereo: 0.06 % (1 kHz)
SUPER NARROW	Mono: 0.2 % (1 kHz)
	Stereo: 0.8 % (1 kHz)
Capture Ratio	
NORMAL	1.0 dB
Alternate Channel Selectivity	
NORMAL	80 dB (400 kHz)
SUPER NARROW	80 dB (300 kHz)
Stereo Separation	60 dB (1 kHz)
	50 dB (20 Hz to 10 kHz)
Frequency Response	± 0.7 dB (20 Hz to 15 kHz)
Image Response Ratio	80 dB
IF Response Ratio	100 dB
AM Suppression Ratio	70 dB
Spurious Response Ratio	80 dB
Subcarrier Product Ratio	60 dB
Muting Threshold	23.2 dBf (4 μ V/75 Ω)
Antenna Input	75 Ω unbalanced

AM Tuner Section

Frequency range	531 kHz to 1,602 kHz (Step 9 kHz)
Sensitivity (IHF, Loop antenna)	150 μ V/m
Selectivity	40 dB
Signal-to-Noise Ratio	50 dB
Image Response Ratio	40 dB
IF Response Ratio	60 dB
Antenna	Loop Antenna

Audio Section

Output (Level/Impedance)	
FM (100% MOD)	HEWZI type: 1000 mV/0.5 k Ω
	HE, HB types: 650 mV/0.9 k Ω
AM (30% MOD)	HEWZI type: 220 mV/0.5 k Ω
	HE, HB types: 150 mV/0.9 k Ω

Miscellaneous

Power requirements	a.c. 240 Volts, 50/60Hz
Power Consumption	20 W
Dimensions	420 (W) x 86 (H) x 316 (D) mm
	16-1/2 (W) x 3-3/8 (H) x 12-7/16 (D) in
Weight (without package)	4.1 kg (9 lb 1 oz)

Furnished Parts

FM T-type Antenna	1
AM Loop Antenna	1
Connecting Cord with Pin Plugs	1
Operating Instructions	1

NOTE:

Specifications and design subject to possible modification without notice due to improvements.